

Memsic 2125 Dual-Axis Accelerometer (#28017)

The Memsic 2125 is a low-cost thermal accelerometer capable of measuring tilt, collision, static and dynamic acceleration, rotation, and vibration with a range of ± 3 g on two axes. Memsic provides the 2125 IC in a surface-mount format. Parallax mounts the circuit on a tiny PCB providing all I/O connections so it can easily be inserted on a breadboard or through-hole prototype area.

Features

- Measures ± 3 g on each axis
- Simple pulse output of g-force for each axis
- Convenient 6-pin 0.1" spacing DIP module
- Analog output of temperature (TOut pin)
- Fully temperature compensated over 0 to 70 °C operating temperature range

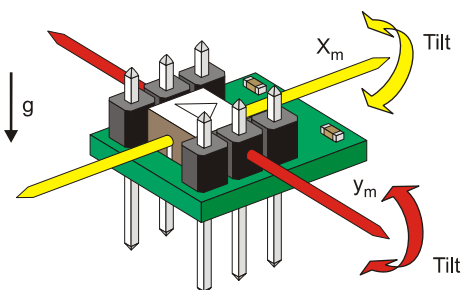

Key Specifications

- Power Requirements: 3.3 to 5 VDC; < 5 mA supply current
- Communication: TTL/CMOS compatible 100 Hz PWM output signal with duty cycle proportional to acceleration
- Dimensions: 0.42 x 0.42 x 0.45 in (10.7 x 10.7 x 11.8 mm)
- Operating temperature: 32 to 158 °F (0 to 70 °C)

Application Ideas

- Dual-axis tilt and acceleration sensing for autonomous robot navigation
- R/C tilt controller or autopilot
- Tilt-sensing Human Interface Device
- Motion/lack-of-motion sensor for alarm system
- Single-axis rotational angle and position sensing

Theory of Operation

The MX2125 has a chamber of gas with a heating element in the center and four temperature sensors around its edge. When the accelerometer is level, the hot gas pocket rises to the top-center of the chamber, and all the sensors will measure the same temperature.

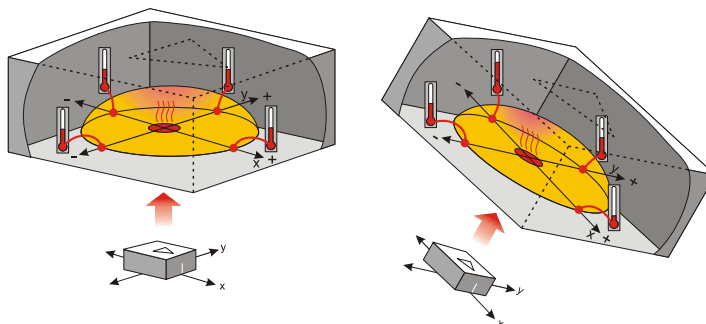

By tilting the accelerometer, the hot gas will collect closer to some of temperature sensors. By comparing the sensor temperatures, both static acceleration (gravity and tilt) and dynamic acceleration (like taking a ride in a car) can be detected. The MX2125 converts the temperature measurements into signals (pulse durations) that are easy for microcontrollers to measure and decipher.

Pin Definitions

For Memsic MXD2125GL pin ratings, see the manufacturer's datasheet posted on the 28017 product page at www.parallax.com.

Pin	Name	Function
1	Tout	Temperature Out
2	Yout	Y-axis PWM output
3	GND	Ground -> 0 V
4	GND	Ground -> 0 V
5	Xout	X-axis PWM output
6	VDD	Input voltage: +3.3 to +5 VDC

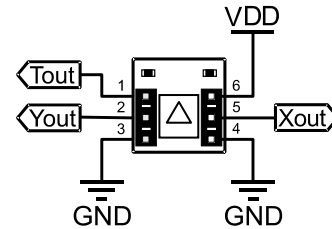

Communication Protocol

Each axis has a 100 Hz PWM duty cycle output in which acceleration is proportional to the ratio t_{Hx}/T_x . In practice, we have found that T_x is consistent so reliable results can be achieved by measuring only the duration of t_{Hx} . This is easy to accomplish with the BASIC Stamp PULSIN command or with the Propeller chip's counter modules.

With $V_{dd} = 5V$, 50% duty cycle corresponds to 0 g, but this will vary with each individual unit within a range of 48.7% to 51.3%. This zero offset may be different when using $V_{dd} = 3.3 V$. See the manufacturer's datasheet for details.

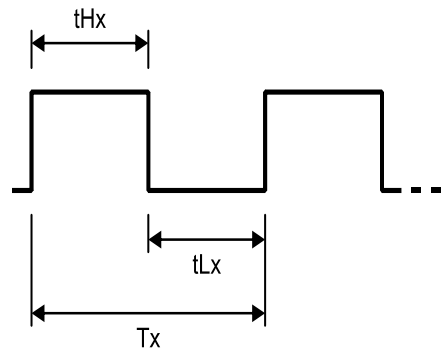

Example Circuit

The example schematic and wiring diagram below are for the BASIC Stamp and Board of Education.

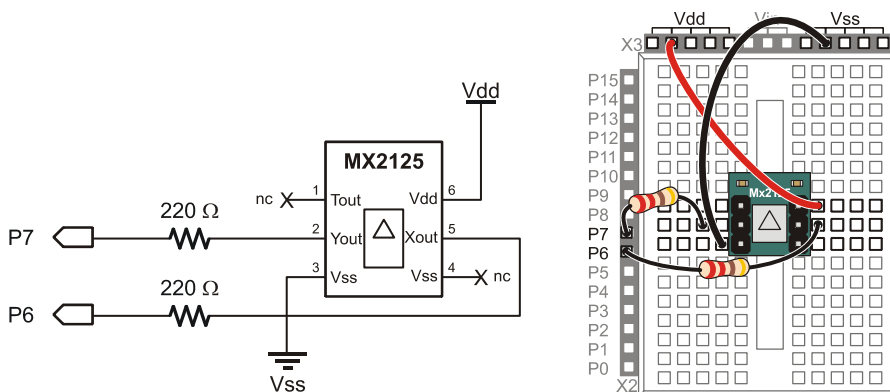

The program below, SimpleTilt.bs2, simply measures the pulse width, that is, the duration of t_{Hx} , for each axis. The raw values are displayed in the BASIC Stamp Editor's Debug Terminal. If you run the program, then tilt the accelerometer, you should see the values for each axis change.

```
' Smart Sensors and Applications - SimpleTilt.bs2
' Measure room temperature tilt.

'{$STAMP BS2}
'{$PBASIC 2.5}

x          VAR      Word
y          VAR      Word

DEBUG CLS

DO

  PULSIN 6, 1, x
  PULSIN 7, 1, y

  DEBUG HOME, DEC4 ? X, DEC4 ? Y

  PAUSE 100

LOOP
```

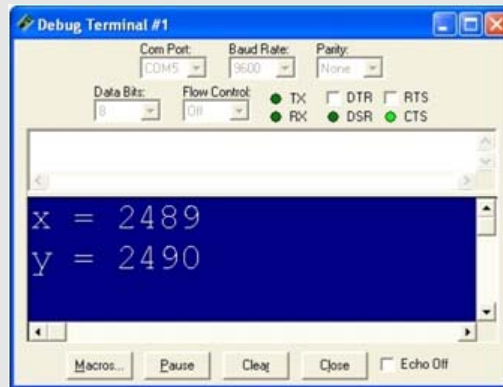

Programming Resources and Downloads

BASIC Stamp

- **Smart Sensors and Applications** — The BASIC Stamp example above is taken from the Stamps in Class text *Smart Sensors and Applications*, which features several chapters specific to the Memsic Dual-Axis Accelerometer. Topics include output scaling and offset, measuring vertical rotation, tilt-controlled video gaming basics, data logging g-force during a skateboard trick, and data logging acceleration on an RC car. The book and sample code can be downloaded from the 28029 product page at <http://www.parallax.com>
- **Boe-Bot Robot Projects with the Memsic 2125 Accelerometer** — The following projects with source code are posted under the Stamps in Class Mini-Projects sticky-thread in the Stamps in Class Forum at <http://forums.parallax.com>:
 - Boe-Bot Robot Navigation with Accelerometer Incline Sensing
 - A Tilt Radio Controller for Your Boe-Bot
- **The Memsic 2125 Demo Kit BASIC Stamp Source Code** — this source code contains conditional compile directives that allow it to be used with the BS2, BS2e, BS2sx, BS2p, and BS2pe.

Propeller Objects

Several Memsic 2125 Accelerometer code objects and applications for the Propeller chip are available in the Propeller Object Exchange (<http://obex.parallax.com>).

Below is a photograph of the high-speed Memsic MXD2125 Accelerometer Demo in action. This application “provides a high speed assembly driver, and separate-cog and same-cog Spin versions of the MXD2125 Dual Axis Accelerometer. The high speed version displays the data on a television as a 3D wireframe plane with normal vector.

